

JØTUL F 620 B

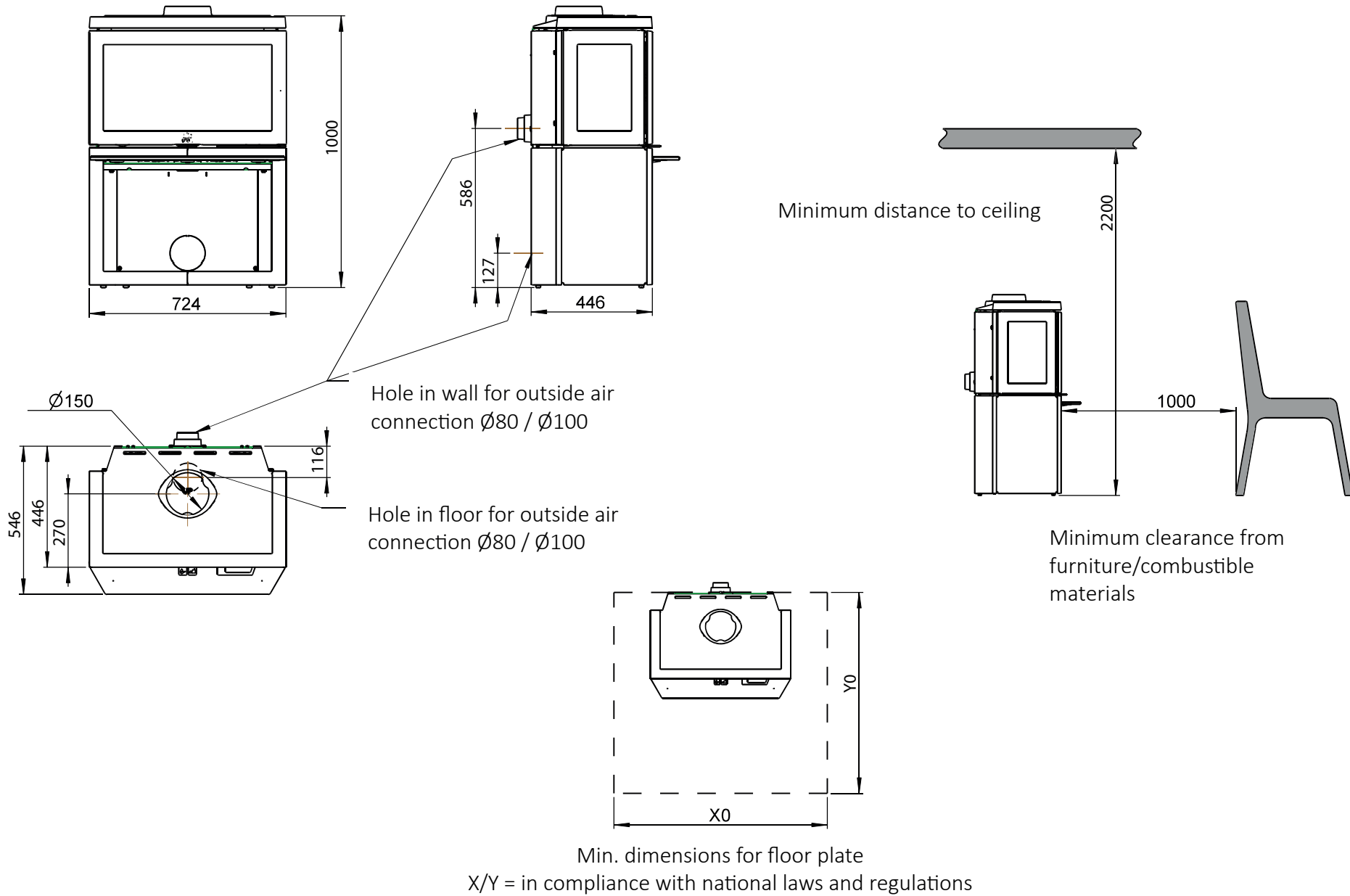

JØTUL F 620 P

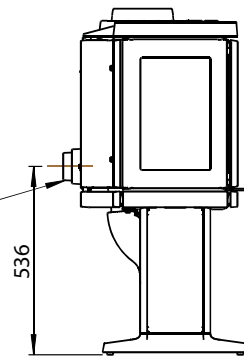
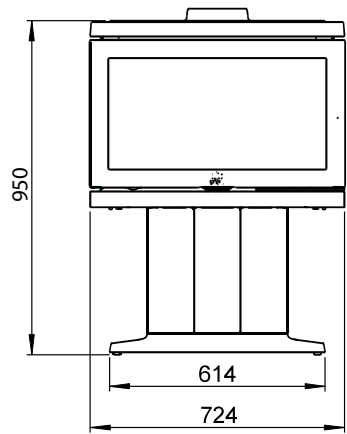

Hole in wall for outside air connection
Ø80 / Ø100

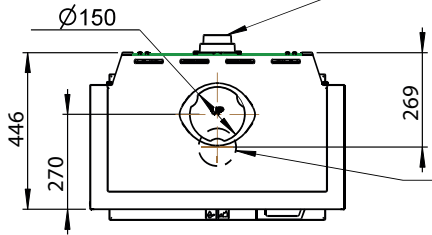

Hole in floor for outside air connection
Ø80 / Ø100

Minimum distance to ceiling

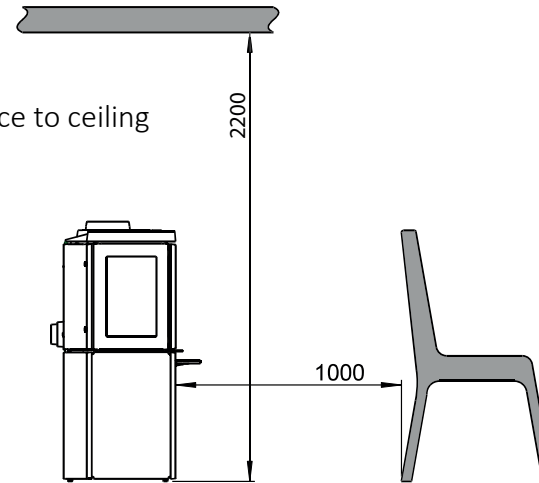

Minimum clearance from
furniture/combustible
materials

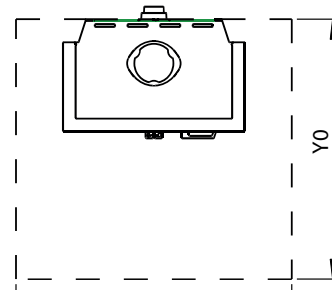

Min. dimensions for floor plate
X/Y = in compliance with national laws and regulations

JØTUL F 620 LB

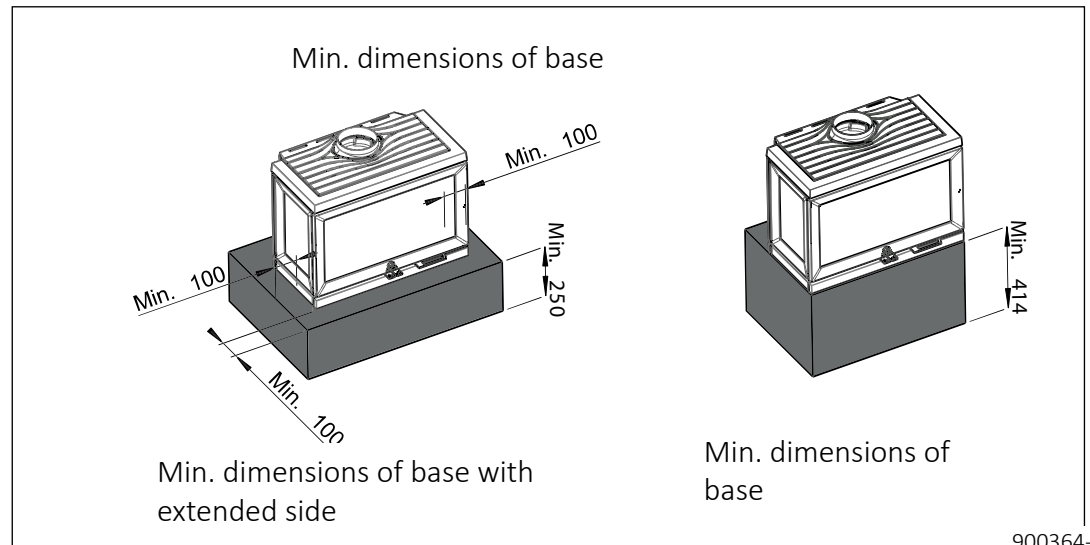
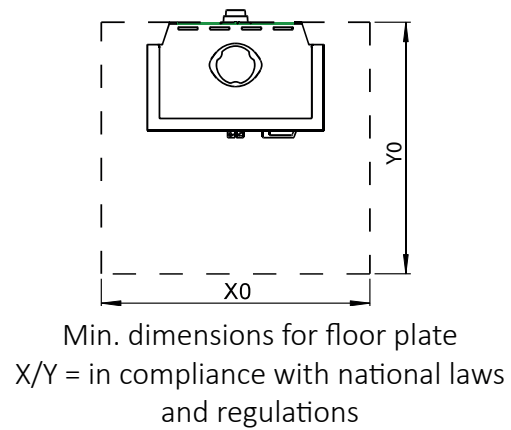
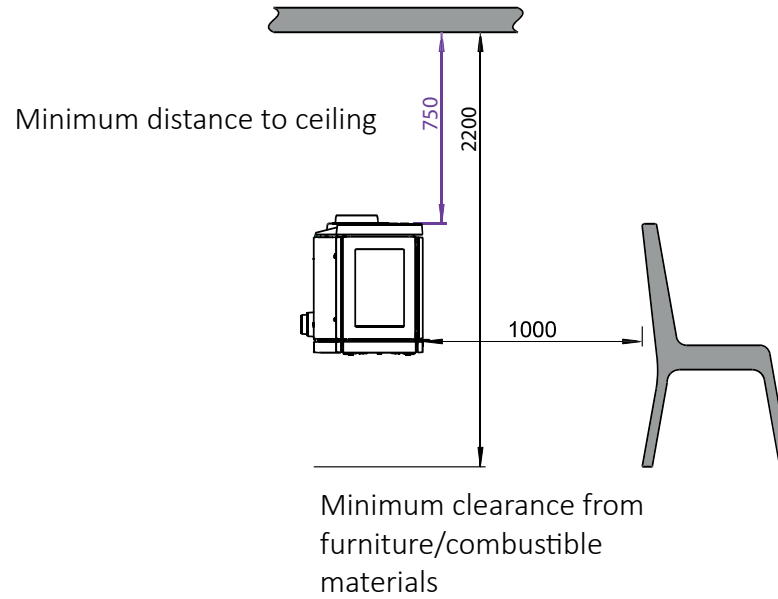
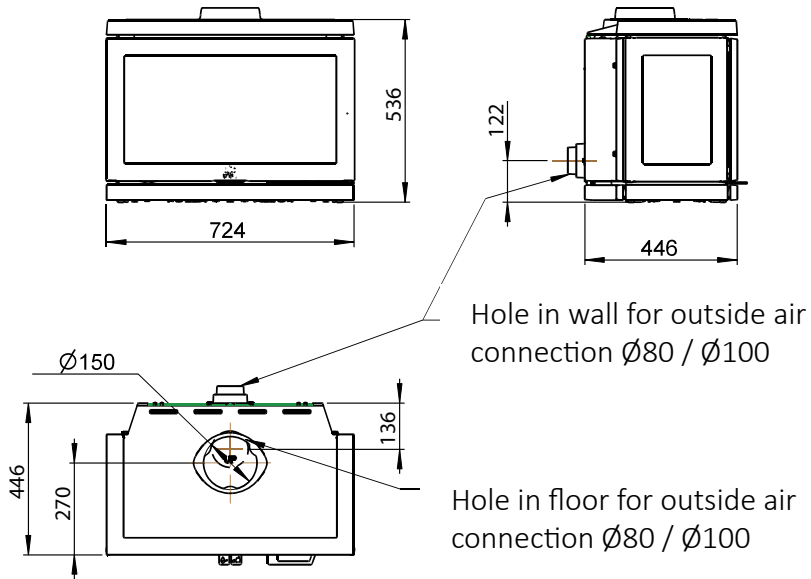

JØTUL F 620 HT

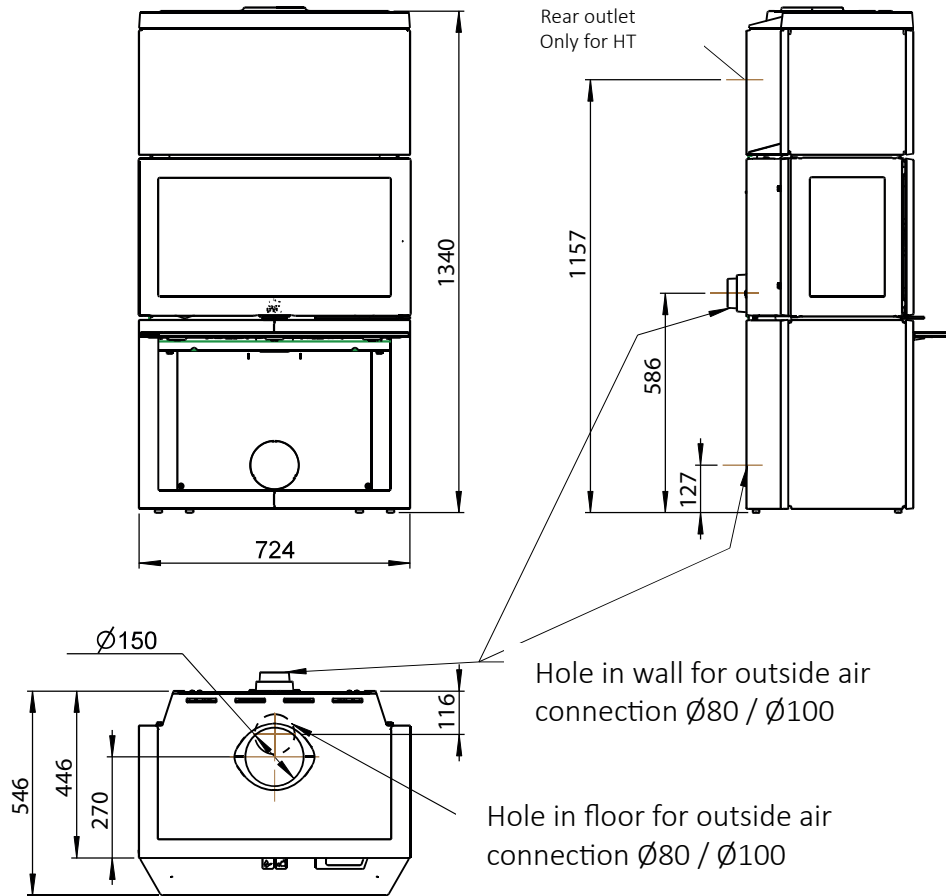

Minimum distance to ceiling

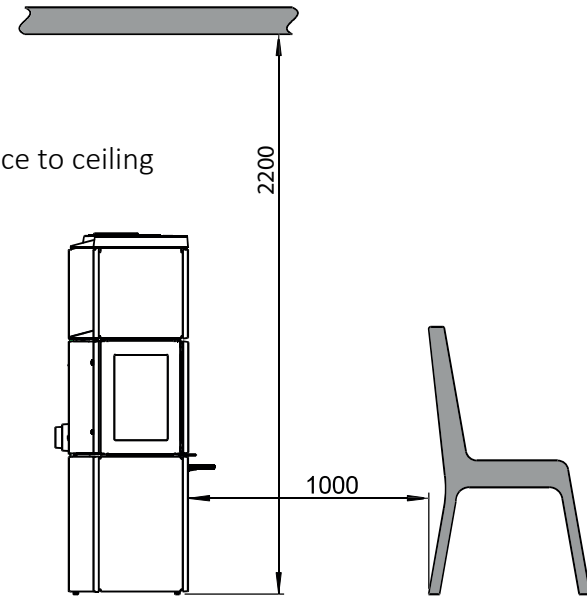

Minimum clearance from furniture/combustible materials

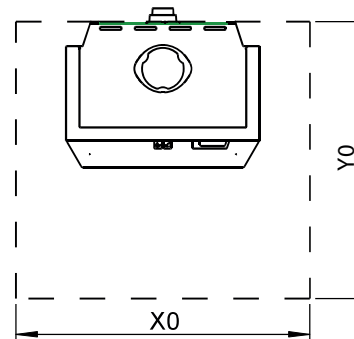

Min. dimensions for floor plate
 X/Y = in compliance with national laws
and regulations

F 620: Minimum distance to combustible wall

With semi-insulated chimney/shielded flue pipe all the way down to the product

 Combustible wall

F 620 B

F 620 P

F 620 LB

F 620 B HT

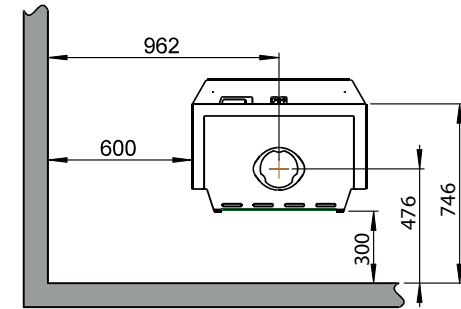
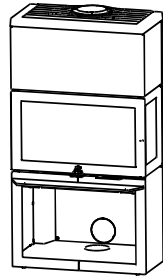
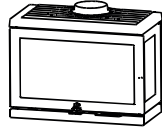
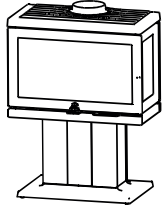
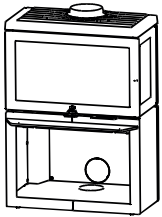

F 620 B / F 620 P / F 620 LB / F 620 B HT
- With retrofitted cast iron side

FR

FL

F

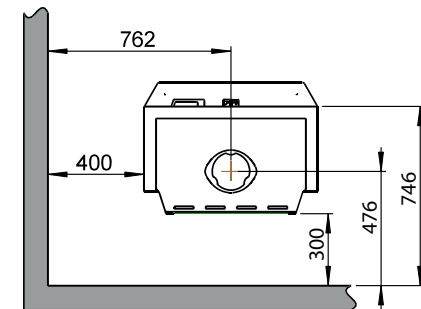
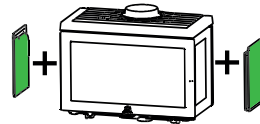
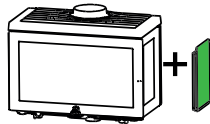
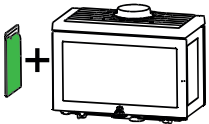

F 620 B / F 620 P / F 620 LB / F 620 B HT
- With retrofitted cast iron side and convection kit side
- With retrofitted convection kit rear

FR
Convection kit side

FL
Convection kit side

Convection kit rear

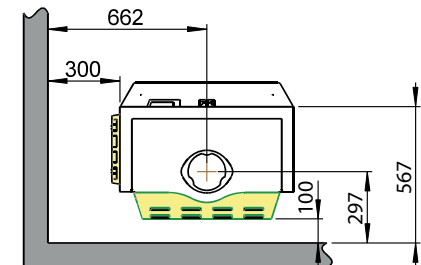
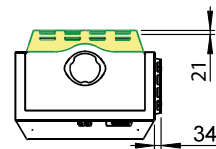
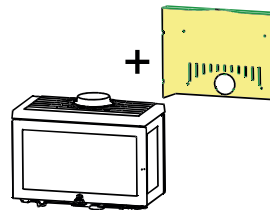
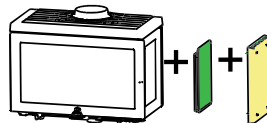
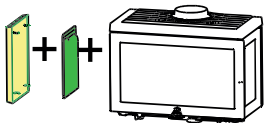

Combustible wall
Firewall (See Chapter 3.3 in the manual)

F 620: Minimum distance to combustible wall protected by approved fireproof wall

F 620 B

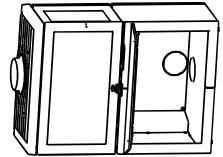

F 620 P

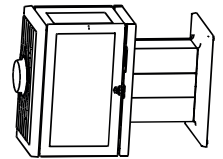

F 620 LB

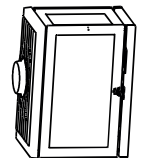

F 620 B HT

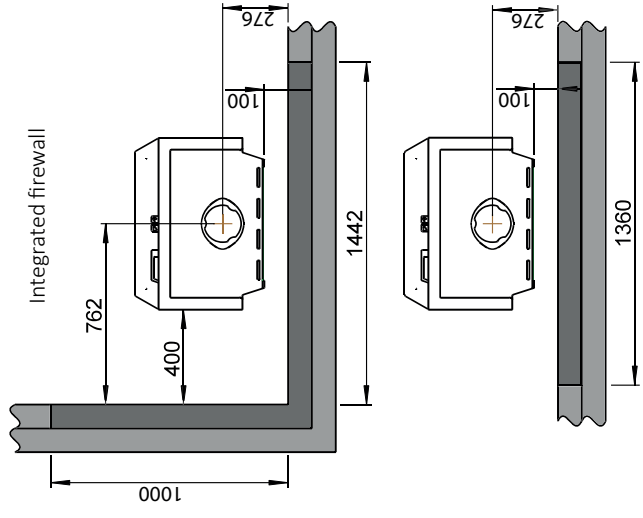
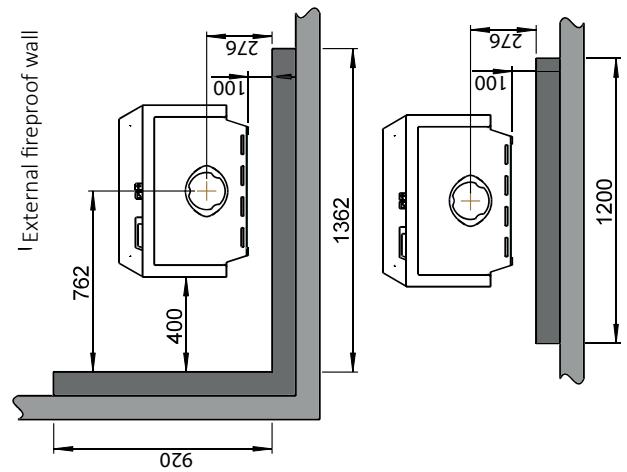
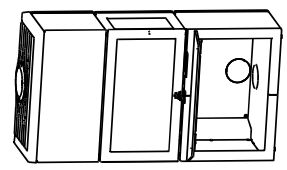

F 620 B / F 620 P / F 620 LB / F 620 HT
- With retrofitted cast iron side

FR

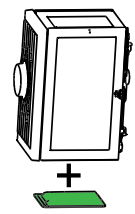

FL

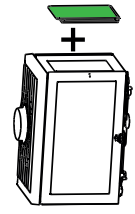

F

